

## FITTING INSTRUCTION

Clamp mark in acc. with		Cables joining
ISO	PN	
1	L	Left directional lights
2	+	Rear fog lights
3	31	Ground
4	R	Right directional lights
5	58R	Right side parking lights
6	54	Stoplights
7	58L	Left side parking lights

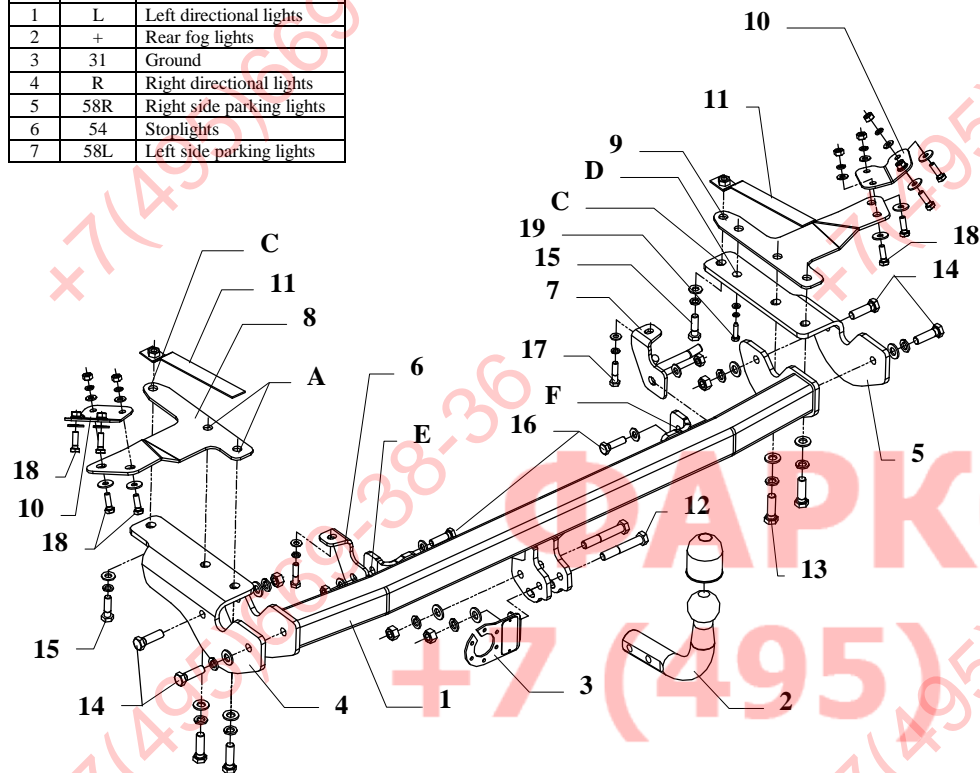

This towing hitch is designed to assembly in following car: **TOYOTA COROLLA VERSO**, produced since 04.2004 till 2007, catalogue no. **O59** and is prepared to tow trailers max total weight **1450 kg** and max vertical load **52 kg**.

### *From manufacturer*

Thank you for buying our product. Their reliability has been confirmed in many tests. Reliability of towing hitch depends also on correct assembly and right operation. For this reasons we kindly ask to read carefully this instruction and apply to hints.

*The towing hitch should be install in points described by a car producer.*

## The instruction of the assembly

1. Disassemble rear bumper.
2. Disassemble original tow handles and metal reinforcement of the bumper.
3. Disassemble muffler and thermal shield.
4. Put elements (pos. 4 and 5) and reinforcements (pos. 8 and 9) in this way, so holes (pos. A) agree with fabric threaded holes and next fix using bolts M12x1,25x40mm (pos. 13) – loosely (see drawing). **Attention!** On the left side fix with original fabric tow eye too.
5. To chassis members put elements (pos. 11 – plate with nut M10) in this way, so nuts agree with holes (pos. C), fix using bolts M10x35mm (pos. 15).
6. Elements (pos. 8 and 9) fix through original holes in body using bolts M8x35mm (pos. 17), use fish-plates (pos. 10).
7. Between mounted elements (pos. 4 and 5) slip the main bar of the towing hitch (pos. 1) and fix it using bolts M12x35mm (pos. 14) as shown in the drawing.
8. Tighten all bolts according to the torque shown in the table.
9. Mount original, metal reinforcement.
10. Assemble thermal shield using three original bolts, fourth (through hole pos. D) take from towing hitch accessories - M6x25mm (pos. 19).
11. Through hole (pos. E) fix handle (pos. 6) using bolt M10x25mm (pos. 16) and to body through original threaded hole using bolt M8x35mm (pos. 17).
12. Through hole (pos. F) fix handle (pos. 7) (with mufflers handle) using bolt M10x25mm (pos. 16) and to body through original threaded hole using bolt M8x35mm (pos. 17).
13. Mount muffler. **Attention!** Last handle of muffler put on handle (pos. 7).
14. Reassemble bumper after cut out its fragment (in lower part, in axis) 50x30mm.
15. Fix tow-ball (pos. 2) and socket plate (pos. 3) using bolts M12x75mm (pos.12) supplied.
16. Connect electric wires of 7-poles socket according to the instruction of the car. (Recommend to make at authorized service station).
17. Complete paint layer damaged during installation.

Torque settings for nuts and bolts (8,8):	
<b>M 8</b> - 25 Nm	<b>M 10</b> - 55 Nm
<b>M 12</b> - 85 Nm	<b>M 14</b> - 135 Nm











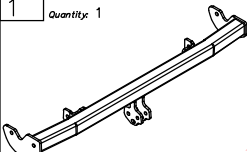











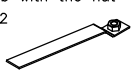

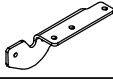
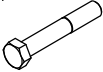

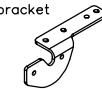

### NOTE

After install the towing hitch you should get adequate note in registration book (at authorised service station).The car should be equipped with:

- Indicators
- Tow mirrors

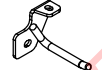
After 1000km of exploitation check all bolts and nuts. The ball of towing hitch must be always kept clear and conserve with a grease.

## Towing hitch accessories:

Pos. 1 Name: Main bar Quantity: 1 	Pos. 8 Name: External left handle Quantity: 1 	Pos. 16 Name: Bolt 8,8 B Quantity: 2 Dim.: M10x25mm 	Pos. 24 Name: Plain washer Quantity: 6 Dim.: Ø 10,5 mm 
	Pos. 9 Name: External right handle Quantity: 1 	Pos. 17 Name: Bolt 8,8 B Quantity: 2 Dim.: M8x35mm 	Pos. 25 Name: Plain washer Quantity: 10 Dim.: Ø 8,5 mm 
Pos. 2 Name: Tow ball Quantity: 1 	Pos. 10 Name: Bent plate Quantity: 2 	Pos. 18 Name: Bolt 8,8 B Quantity: 8 Dim.: M8x30mm 	Pos. 26 Name: Plain washer Quantity: 1 Dim.: Ø 6,5 mm 
Pos. 3 Name: Socket plate Quantity: 1 	Pos. 11 Name: Jib with the nut Quantity: 2 	Pos. 19 Name: Bolt 8,8 B Quantity: 1 Dim.: M6x25mm 	Pos. 27 Name: Spring washer Quantity: 10 Dim.: Ø 12,2 mm 
Pos. 4 Name: Left bracket Quantity: 1 	Pos. 12 Name: Bolt 8,8 B Quantity: 2 Dim.: M12x75mm 	Pos. 20 Name: Nut 8 B Quantity: 4 Dim.: M12 	Pos. 28 Name: Spring washer Quantity: 2 Dim.: Ø 10,2 mm 
Pos. 5 Name: Right bracket Quantity: 1 	Pos. 13 Name: Bolt 8,8 B Quantity: 4 Dim.: M12x1,25x40mm 	Pos. 21 Name: Nut 8 B Quantity: 2 Dim.: M10 	Pos. 29 Name: Spring washer Quantity: 10 Dim.: Ø 8,2 mm 
Pos. 6 Name: Internal left handle Quantity: 1 	Pos. 14 Name: Bolt 8,8 B Quantity: 4 Dim.: M12x35mm 	Pos. 22 Name: Nut 8 B Quantity: 8 Dim.: M8 	Pos. 30 Name: Spring washer Quantity: 1 Dim.: Ø 6,2 mm 
Pos. 7 Name: Internal right handle Quantity: 1 	Pos. 15 Name: Bolt 8,8 B Quantity: 2 Dim.: M10x35mm 	Pos. 23 Name: Plain washer Quantity: 10 Dim.: Ø 13 mm 	Pos. 31 Name: Ball cover Quantity: 1 



**PPUH AUTO-HAK S.J.**

Produkcja Zaczepów Kulowych  
Henryk & Zbigniew Nejman  
76-200 SŁUPSK ul. Słoneczna 16K  
tel/fax (059) 8-414-414; 8-414-413  
E-mail: office@autohak.com.pl  
www.autohak.com.pl

## Towing hitch (without electrical set)

Class: **A50-X** Cat. no. **O59**

Designed for:

Manufacturer: **TOYOTA**

Model: **COROLLA**

Type: **VERSO**

produced since 04.2004 till 2007

Technical data:

**D-value: 8,6 kN**

maximum trailer weight: **1450 kg**

maximum vertical cup load: **52 kg**

Approval number acc. to regulations EKG/ONZ 55.01: **E20-55R-01 1344**

## Foreword

This towing hitch is designed according to rules of safety traffic regulations. The towing hitch is a safety component and can be install only by qualified personnel. Any alteration or conversion of the towing hitch is prohibited and would lead to cancellation of design certification. Remove insulating compound and underseal from vehicle (if present) in the area of the matting surfaces of the towing hitch. The vehicle manufacturer's specifications regarding trailer load and max. vertical cup load are decisive for driving whereat values for the towing hitch cannot be exceeded.

*D-value formula:*

$$\frac{\text{Max trailer weight [kg]} \times \text{Max vehicle weight [kg]} \times \frac{9,81}{1000}}{\text{Max trailer weight [kg]} + \text{Max vehicle weight [kg]}} = D \text{ [kN]}$$